

DETAIL A  
SCALE 1.250  
(ALL DIMS THIS VIEW ARE 4X)

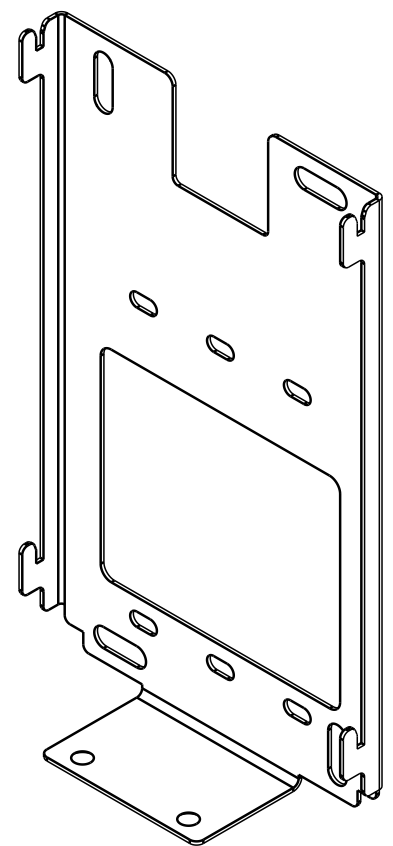

|                     |      |                           |   |   |
|---------------------|------|---------------------------|---|---|
| MATERIAL            |      | 304 SS 18 GA (.048 THICK) |   |   |
| FINISH              |      | DEBURR PRIOR TO BENDING   |   |   |
|                     | INIT | DATE                      | <b>STONELOCK</b><br>12635 Hemlock Street<br>Overland Park KS 66213<br>www.stonelock.com | TOLERANCES UNLESS OTHERWISE SPECIFIED<br>SHTMTL BENDS OTHER<br>.XX ±.030 ±.015<br>.XXX ±.015 ±.005<br>ANG ±2° ±.5°<br><br>FINISH 125 μIN<br>BREAK EDGES R.005-R.010 |
| DWN                 | WRH  | 11/21/19                  |   |   |
| CHK                 |      |                           |   |   |
| ENG                 |      |                           |   |   |
| MAT                 |      |                           |   |   |
| MODEL FILE          |      | 27692                     |   | MODEL TYPE  |
|                     |      |                           |   | PART  |
| TITLE               |      |                           |   |   |
| WALL MOUNT, BETA    |      |                           |   |   |
| PART NUMBER         |      | SCALE                     |   | SIZE  |
| 047-0202-0002 27692 |      | 0.625                     |   | B   |
|                     |      | SHT 1 OF 2                |   | REV   |
|                     |      |                           |   | F   |

|     |  |          |      |        |
|-----|--|----------|------|--------|
| F   | NARROWED BOTTOM FLANGE,<br>LOWERED TOP NOTCH,<br>INCREASED WINDOW HEIGHT | 04/28/20 | JHH  |        |
| REV | DESCRIPTION  | DATE     | INIT | ECN NO |

CONFIDENTIAL AND PROPRIETARY MATERIAL

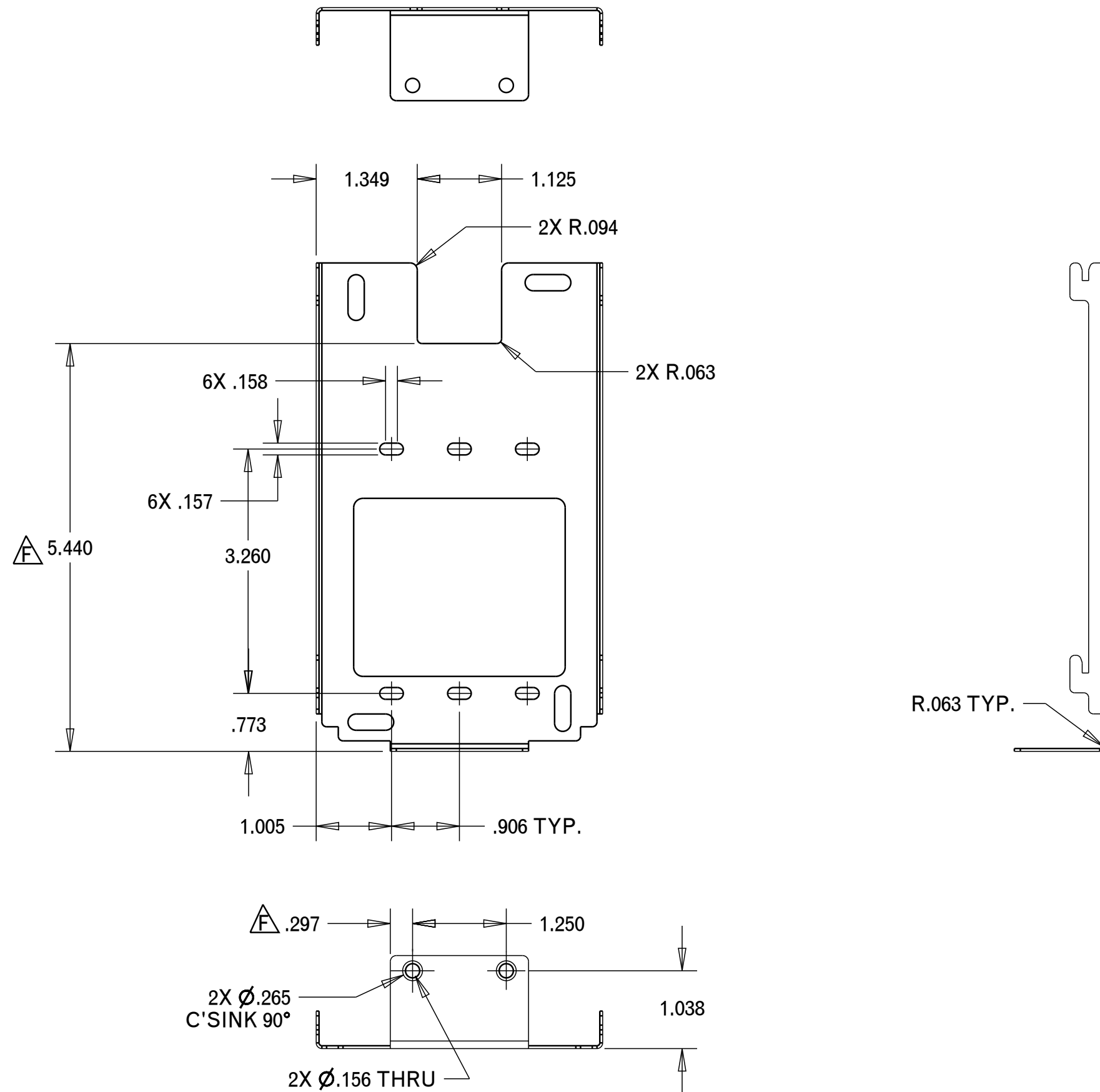

|                  |                                    |          |
|------------------|------------------------------------|----------|
| <b>STONELOCK</b> |                                    |          |
| SHEET<br>2 OF 2  | PART NUMBER<br>047-0202-0002 27692 | REV<br>F |